

## Model DPA2H

- Band II panel
- Broadband 87.5÷108 MHz
- Demountable
- Horizontal polarization
- Directional pattern
- Suitable as a component in various array

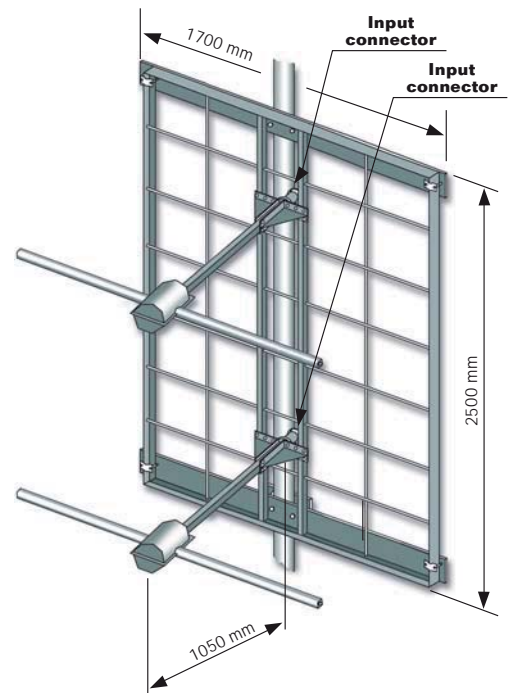

ELECTRICAL DATA	
Frequency range	87.5÷108 MHz
Impedance	50 Ohm
Connectors	Two input connectors Type N or 7/16" or 7/8" EIA
Max Power	2x800W (N) – 2x2KW (7/16") 2x3.5KW (7/8" EIA)
VSWR	≤ 1.3:1
Polarization	Horizontal
Gain	7.5 dB (referred to half-wave dipole)
Half power beam width	E plane ± 35° H plane ± 28°
Lightning protection	All metal parts DC grounded

MECHANICAL DATA	
Dimensions	2500x1700x1050 mm
Weight	75 kg
Wind surface	0.77 m <sup>2</sup> (front) 0.13 m <sup>2</sup> (side)
Wind load	148 kg (front - wind speed at 160 km/h)
Max wind velocity	200 km/h.
Materials	Reflector: hot dip. galvanized steel Radiating dipoles: stainless steel Internal parts: passivated aluminium Radome: fiberglass (option)
Icing protection	Feed point radome (optional)
Radome	Optional
Mounting	With special pipe clamps 50÷110 mm dia.

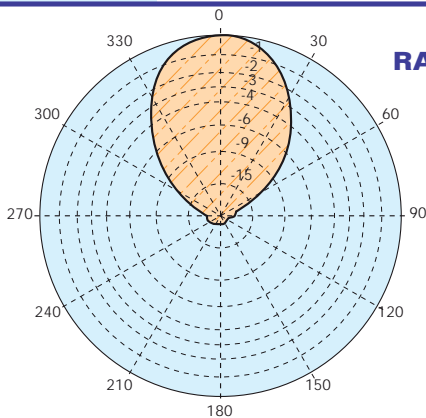

E-Plane

### RADIATION PATTERN (MID BAND)

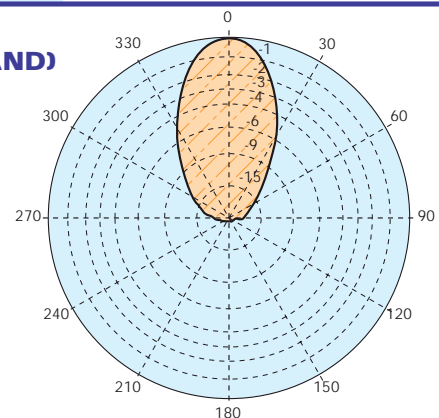

H-Plane

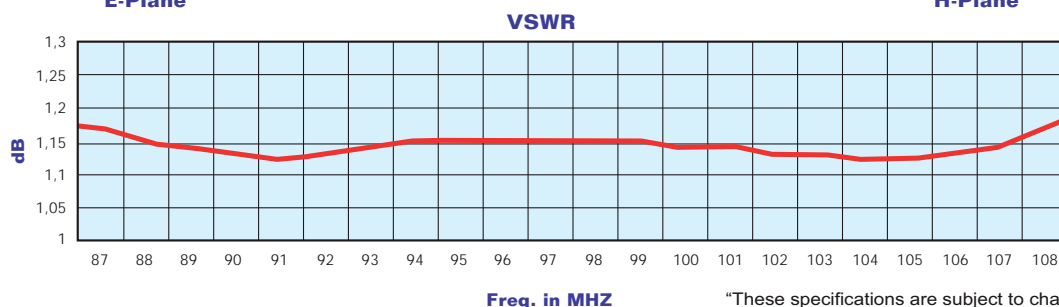

Freq. in MHz

"These specifications are subject to change without notice"

## Model DPA2H

**Radiations systems with DPA2H panel**  
**Omnidirectional or directional pattern**  
**Balanced or unbalanced splitting power**  
**High power system**  
**Broadband 87.5÷108 MHz**

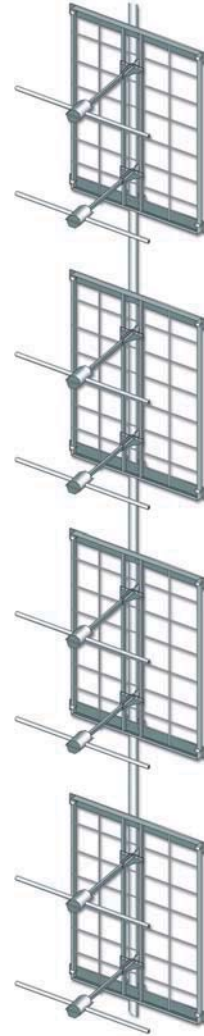

### ELECTRICAL DATA

Frequency range	87.5÷108 MHz
Impedance	50 Ohm
Connector	EIA flange according to system power rating
VSWR	≤ 1.3:1 Max
Polarization	Horizontal
Gain	According to requirement
Horizontal pattern	Any type according to requirements
Vertical pattern	Null fill, beam tilt and special requirements to order
Other facilities	The antenna system can be supplied in split feed with two equal half antennas. Each half can accept full power

### MECHANICAL DATA

Height of array	Subject to number of bays ( refer to table )
Total net weight	Refer to table
Wind load	Refer to table
Pressurizable	Yes
Radome	Optional
Mounting hardware	Hot dip galvanized steel clamps
Shipping	As required

### HORIZONTAL PATTERNS WITH 2, 3 AND 4 FACES AT 98 MHz

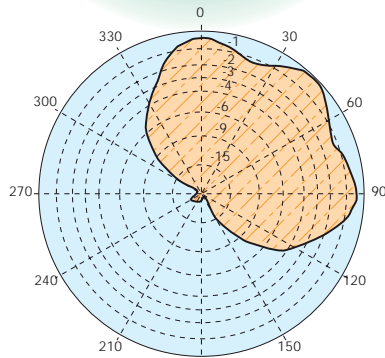
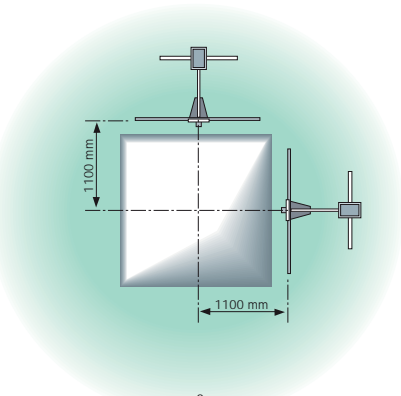

H-Plane

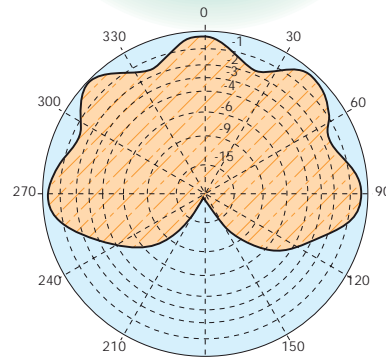
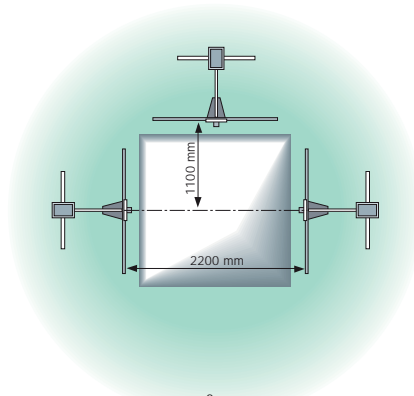

H-Plane

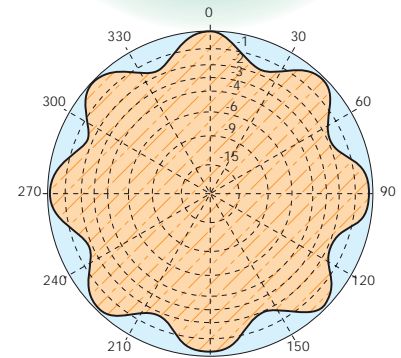
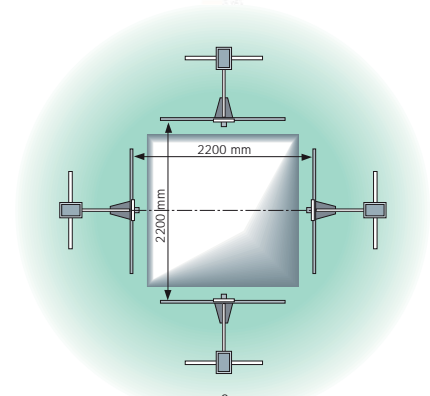

H-Plane

"These specifications are subject to change without notice"

## Model DPA2H

### TECHNICAL DATA

Number of bays	Panels per bay	Gain <sup>1</sup>		Weight <sup>2</sup> kg	Antenna height L m	Wind load <sup>3</sup> (v=160 km/h) kg
		dB	times			
1	2	4.9	3.1	150	2.5	174
	3	2.8	2.1	225		199
	4	1.3	1.6	300		236
2	1	10.5	13.2	150	5.7	196
	2	7.8	6.5	300		348
	3	5.9	4.5	450		398
	4	4.3	3.3	600		472
4	1	13.5	26.2	300	12.1	592
	2	10.8	13.2	600		696
	3	8.9	9.2	900		796
	4	7.3	6.7	1200		944
6	1	15.3	39.8	450	18.5	888
	2	12.6	20.0	900		1044
	3	10.7	13.7	1350		1194
	4	9.1	10.0	1800		1416
8	1	15.9	55.0	600	24.9	1184
	2	13.8	27.6	1200		1392
	3	11.9	18.3	1800		1592
	4	10.3	13.7	2400		1888

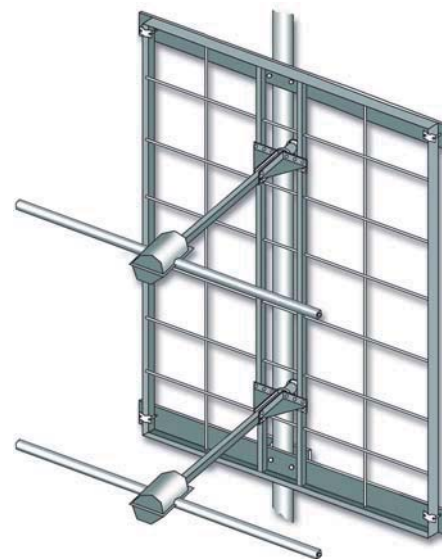

<sup>1</sup> Referred to a half wave dipole. Attenuation of connecting cables not taken into account.

<sup>2</sup> Without mounting hardware.

<sup>3</sup> According to the tower type, for more details contact us.

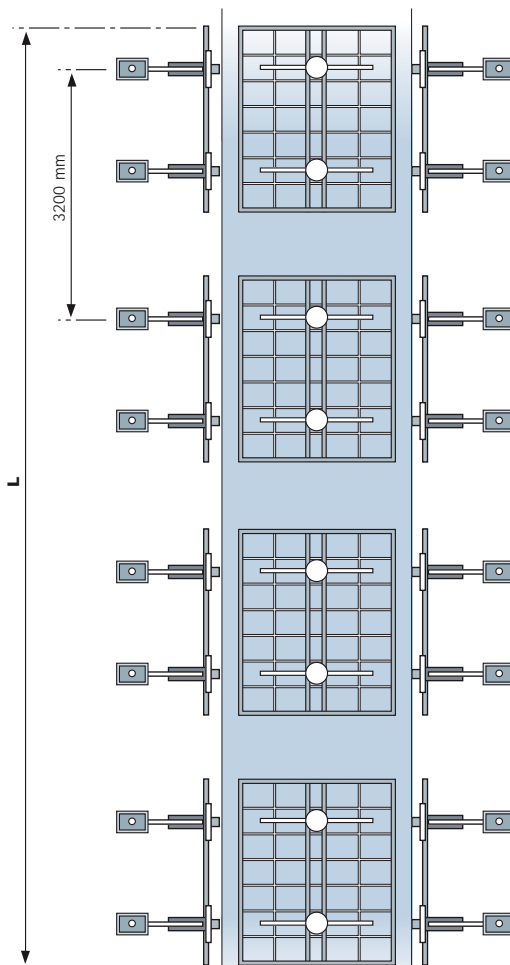
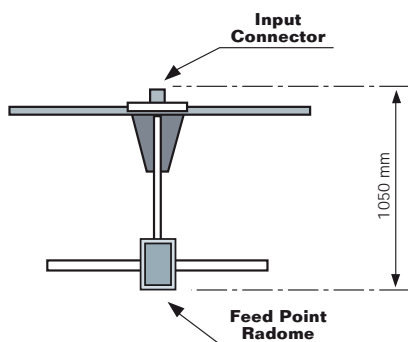
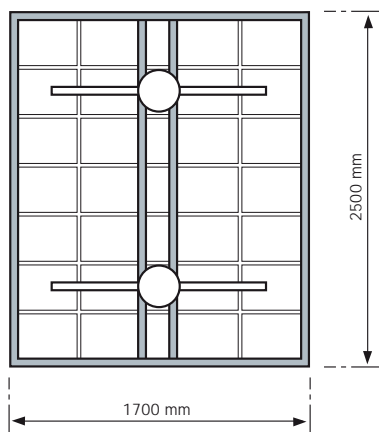

"These specifications are subject to change without notice"

## Model DPA2H

### VERTICAL PATTERN

— Without null fill  
— With null fill and beam tilt

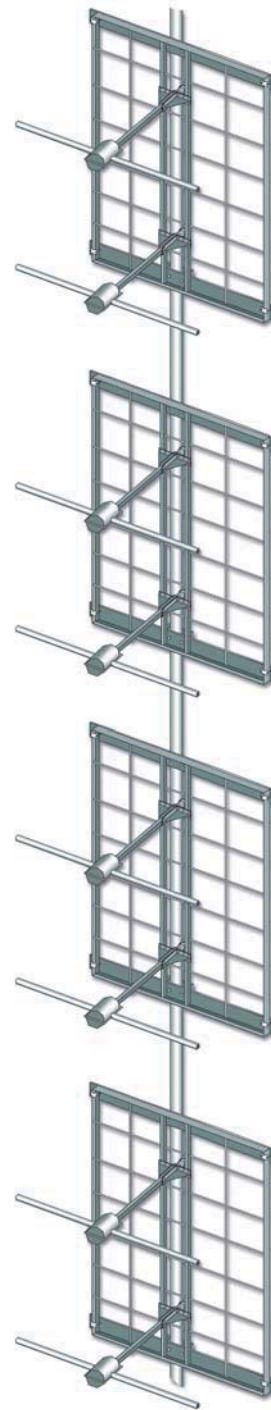
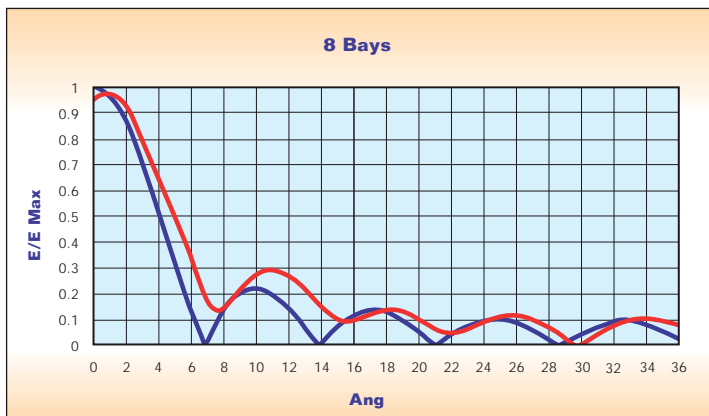
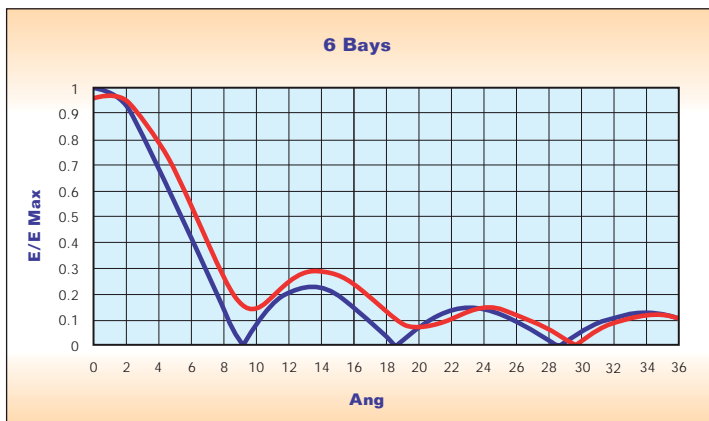
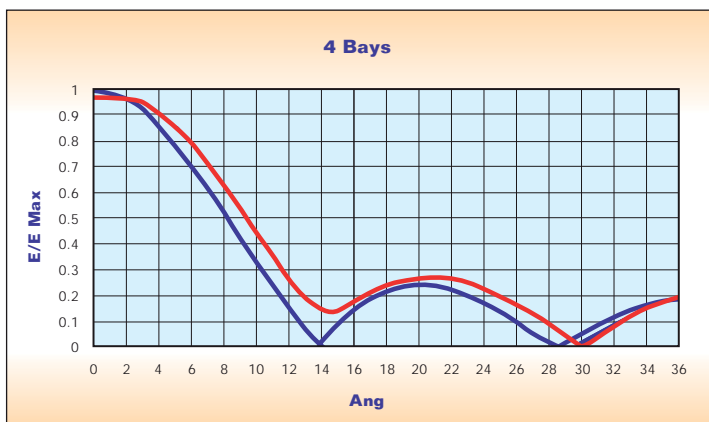
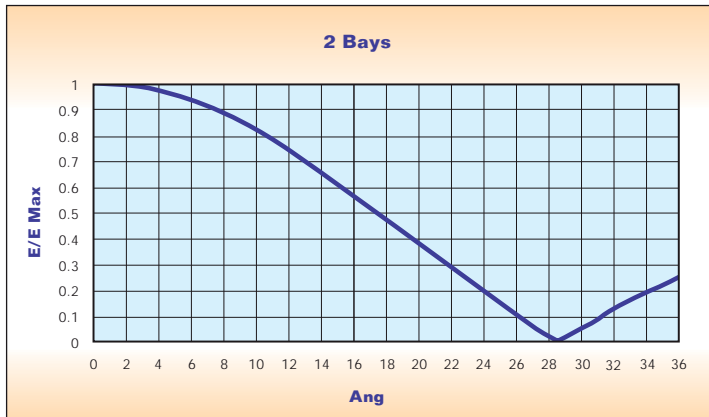

- Gain is provided for horizontal polarization.
- If the antenna is side mounted, the supporting structure will have a slight effect on the radiation pattern and VSWR.
- Vertical tower space, wind load and weight numbers given are typical. Actual values vary with the specific installation. Contact us for more details of your installation.
- Gain will be reduced if null fill, beam tilt or special wavelength spacing is provided.
- Antenna radiation aperture is the distance from the centre of the top bay to the centre of the bottom bay.
- Five ft(1.6mt) of pipe required above the top bay and below the bottom bay for to protect from pattern interference by other antennas.
- Antenna wind load is calculated for 100 Mph (160Km/h) per EIA-222-C standard.

"These specifications are subject to change without notice"